



GLF4000, GLF4001

Ultra-Low Current Consumption Power Multiplexer Switch with Auto & Manual Input Selection in SOT23-6L

Product Specification

DESCRIPTION

The GLF4000 and GLF4001 are integrated power multiplexer switch with dual independent power switches connected to a single output pin to enable seamless transition between two input sources.

The GLF4000 and GLF4001 provide an automatic selection mode as well as a manual selection mode by the combination of the logic input pins of EN and SEL. The EN input pin is used along with the select (SEL) input pin to select the automatic switching function, select VIN1 only, select VIN2 only, or turn both switches off. In the automatic selection mode, the GLF4000 and GLF4001 automatically select the higher input voltage source out of two input DC power supplies.

The GLF4000 and GLF4001 feature an ultra-efficient I_{QSmart}^{TM} technology that offers quiescent current (I_Q) and shutdown current (I_{SD}) in the industry. Low R_{ON} reduces conduction losses while low I_Q and I_{SD} solutions help designers to reduce parasitic leakage current, improve system efficiency, and increase battery lifetime.

The GLF4000 and GLF4001 block any cross-conduction current between two input power sources. When the switch is disabled, the GLF4000 and GLF4001 prevent the reverse current to the input source from the output at any higher V_{out} than V_{in} condition.

FEATURES

- Two-Input and Single-Output Power Multiplexer Switch
- Automatic and Manual Input Selection Mode
- Supply Voltage Range: 1.5 V to 5.5 V
6 Vabs Max
- R_{ON} : 68 m Ω Typ. at 5.5 V_{IN1} or V_{IN2}
77 m Ω Typ. at 3.3 V_{IN1} or V_{IN2}
- 2 A Continuous Output Current Capability Per Channel
- Ultra-Low Supply Current at Operation
 I_Q : 4 μ A Typ at 5.5 V_{IN}
- Ultra-Low Stand-by Current
 I_{SD} : 20 nA Typ at 5.5 V_{IN}
- Smart Control Pins
 I_{EN} and I_{SEL} : 3 nA Typ at V_{EN} or $V_{SEL} > V_{IH}$
 R_{EN} and R_{SEL} : 500 k Ω Typ
- Integrated Output Discharge Switch: GLF4000
- No Cross Conduction Between Two Inputs
- Reverse Current Blocking when Disabled
- Operating Temperature Range: -40 °C to 85 °C
- HBM: ± 6 kV, CDM: ± 2 kV

APPLICATIONS

- Smart IoT Devices
- Wearables / Portable Devices
- Headset and Audio System
- Backup Power System

PACKAGE

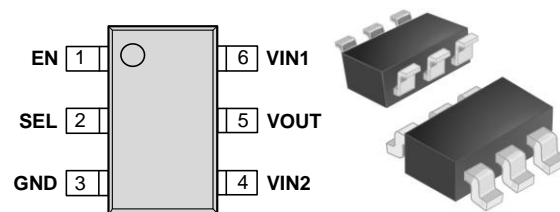

SOT23-6L

DEVICE ORDERING INFORMATION

Part Number	Top Mark	R _{ON} at 5.5 V _{IN}	Output Discharge	Output Current, I _{OUT}	Ultra-low I _Q at 5.5 V _{IN}
GLF4000-T2G7	BX	68 mΩ	70 Ω	2 A	4 μA
GLF4001-T2G7	AR		NA		

PACKAGE OUTLINE

Size Mark	Min (mm)	Max (mm)	Size Mark	Min (mm)	Max (mm)
A	2.82	3.02	C	1.05	1.15
e	0.95 (BSC)		C1	0.03	0.15
b	0.28	0.45	C2	0.12	0.23
B	1.50	1.70	L	0.35	0.55
B1	2.60	3.00	θ	0°	8°

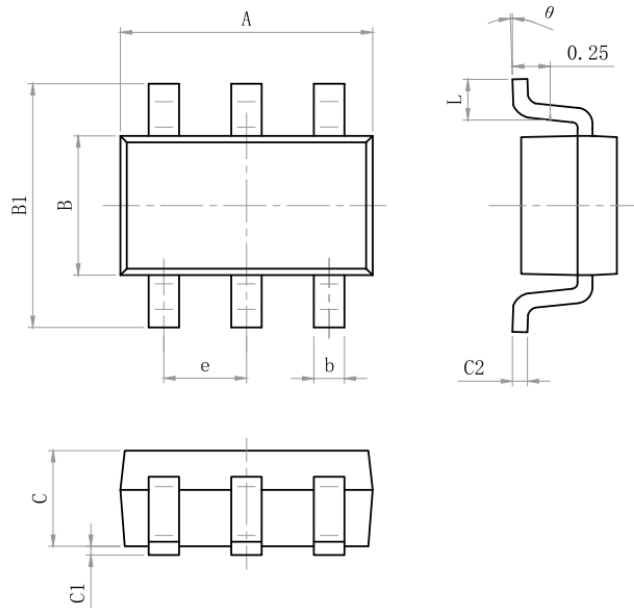

Recommended Footprint

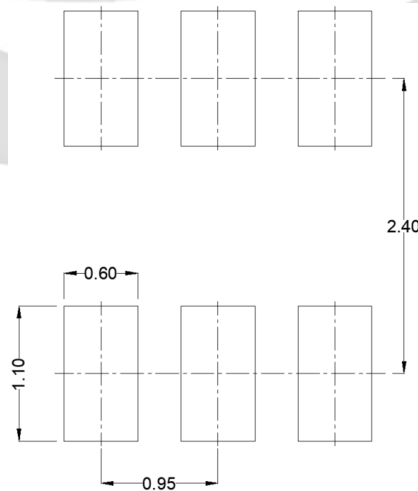

TAPE AND REEL INFORMATION

REEL DIMENSIONS

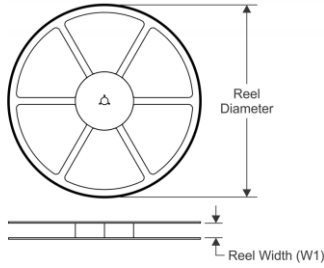

QUADRANT ASSIGNMENTS PIN 1 ORIENTATION TAPE

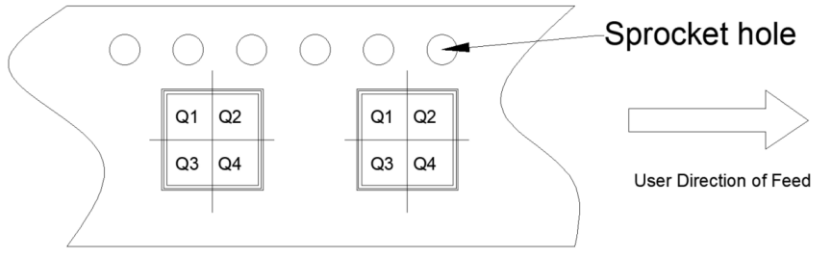

TAPE DIMENSIONS

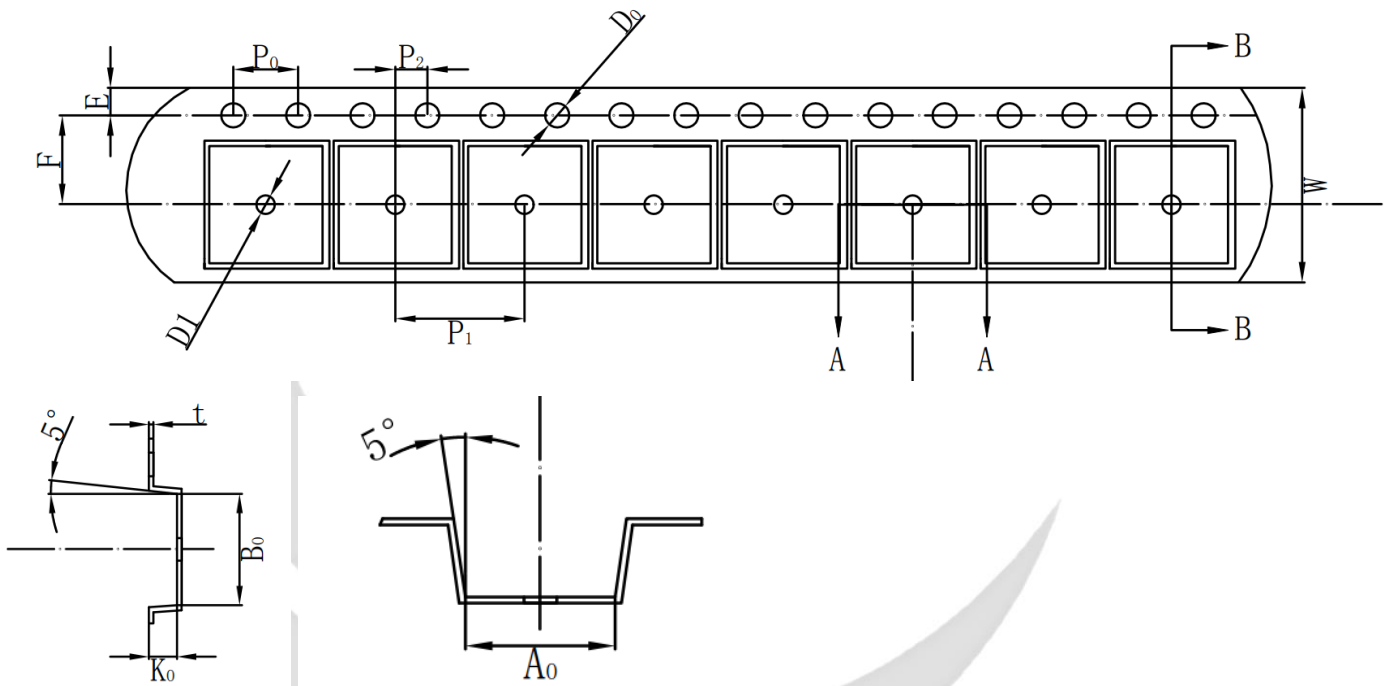

Device	Package	Pins	SPQ	Reel Diameter(mm)	Reel Width W1	A0	B0	K0	P1	W	Pin1
GLF4000-T2G7	SOT23-6	6	3000	178	9	3.25	3.30	1.38	4	8	Q3
GLF4001-T2G7	SOT23-6	6	3000	178	9	3.25	3.30	1.38	4	8	Q3

Remark:

- A0: Dimension designed to accommodate the component width
- B0: Dimension designed to accommodate the component length
- C0: Dimension designed to accommodate the component thickness
- W: Overall width of the carrier tape
- P: Pitch between successive cavity centers